

INTERFACE:	
1	VSS
2	VDD(5V)
3	CS
4	SID
5	SCLK
6	FG / V0
7	/RST
8	LED-A(5V)
9	LED-K

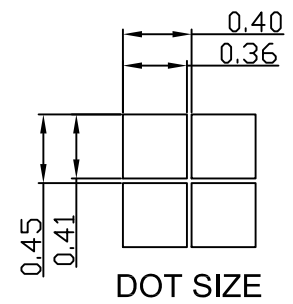
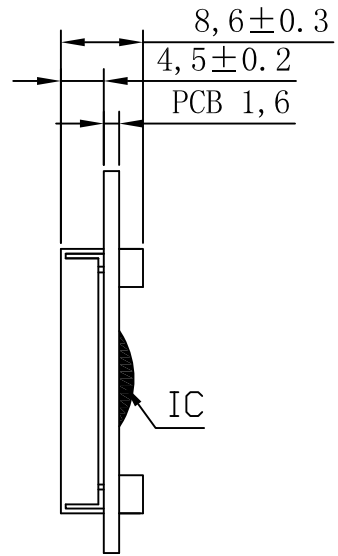
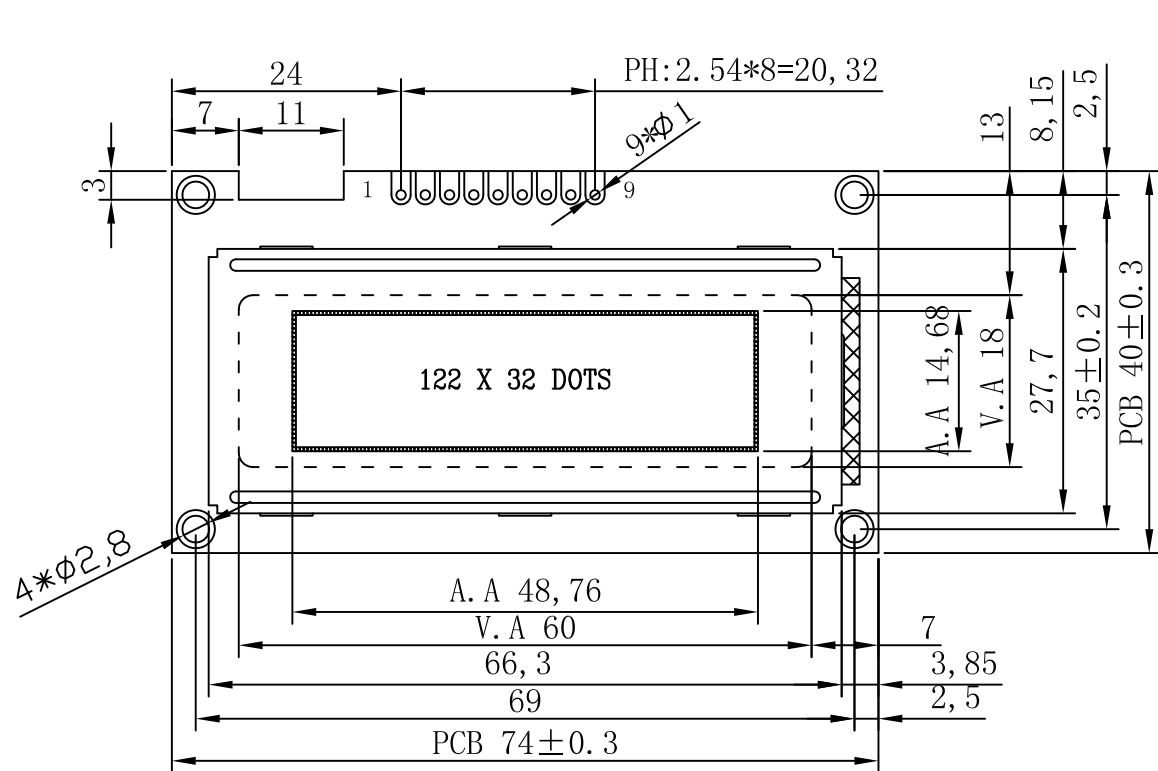

Customer's Choices:

DISPLAY TYPE:	
View angle:	
Temp:	
Voltage:	
IC:	
Backlight:	
Other:	

NOTES:

- | | |
|----------------------------|-------------------------------------|
| 01. DISPLAY TYPE: | STN-BLUE/NEGATIVE/TRANSMISSIVE RoHS |
| 02. OPERATING VOLTAGE: | VOP=4.8V,VDD=5.0V |
| 03. OPERATING TEMPERATURE: | -20°C~+70°C |
| 04. STORAGE TEMPERATURE: | -30°C~+80°C |
| 05. DRIVE MODE: | 1/32DUTY,1/5BIAS |
| 06. VIEWING DIRECTION: | 6:00 |
| 07. DRIVE IC: | AIP31020(OR-EQV) |
| 08. CONNECTOR: | ZEBER |
| 09. BACKLIGHT: | LED(WHITE) |
| 10. CUSTOMER'S PART ID: | BLAZE_STANDARD_PRODUCT |

BLAZE Blaze Display Technology Co.,Ltd.

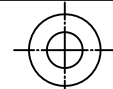
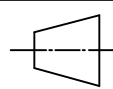
DESIGNED BY: BDT-11	BGB12232-03-SERIES	VERSION: 1.0
CHECKED BY: BDT-07	 	PAGE 1 OF 1
APPROVED BY: BDT-02		UNIT: mm
Website: http://www.blazedisplay.com		DATE: 2011-09-21