

Revised Record

1.0

New issue

2010-4-11

INTERFACE:

J1 (并口)		J2 (串口)	
1	VSS	17	VSS
2	VDD(5V)	18	VDD(5V)
3	VO	19	V0
4	RS	20	SCLK
5	/RW	21	SID
6	E	22	CS
7	DB0	23	LED-A(5V)
8	DB1	24	LED-K
9	DB2		
10	DB3		
11	DB4		
12	DB5		
13	DB6		
14	DB7		
15	LED-A(5V)		
16	LED-K		

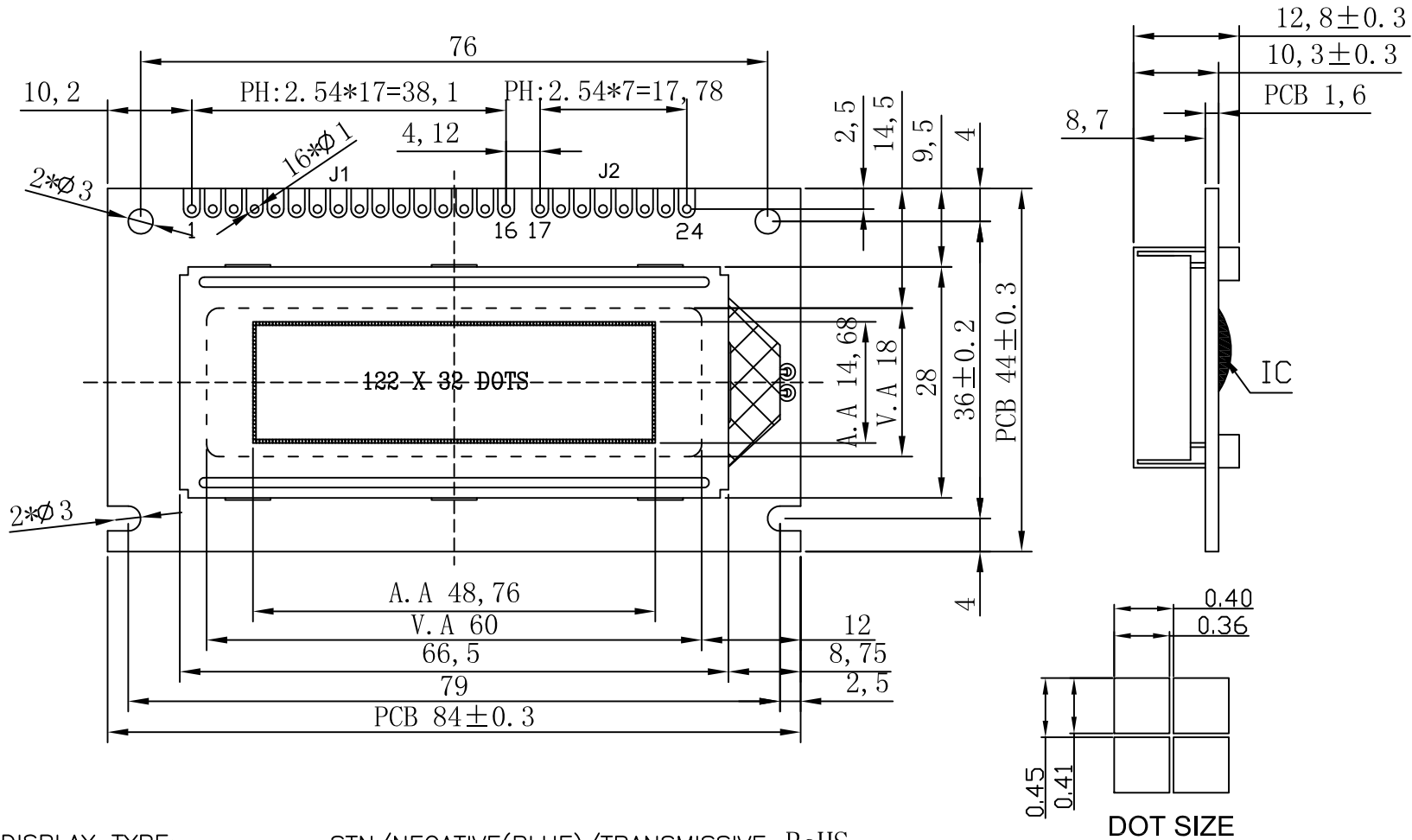

NOTES:

- 01. DISPLAY TYPE: STN/NEGATIVE(BLUE)/TRANSMISSIVE RoHS
- 02. OPERATING VOLTAGE: VOP=4.8V,VDD=5.0V
- 03. OPERATING TEMPERATURE: -20°C~+70°C
- 04. STORAGE TEMPERATURE: -30°C~+80°C
- 05. DRIVE MODE: 1/32DUTY,1/5BIAS
- 06. VIEWING DIRECTION: 6:00
- 07. DRIVE IC: AIP31020
- 08. CONNECTOR: ZEBER
- 09. BACKLIGHT: LED(WHITE)
- 10. CUSTOMER'S PART ID: BLAZE_STANDARD_PRODUCT

BLAZE Blaze Display Technology Co.,Ltd.

DESIGNED BY: BDT-20

BGB12232-10-SERIES

VERSION: 1.0

CHECKED BY: BDT-07

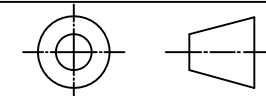

PAGE 1 OF 1

APPROVED BY: BDT-02

UNIT: mm

Website: <http://www.blazedisplay.com>

DATE: 2010-4-11