

Revised Record

1.0

New issue

2012-04-27

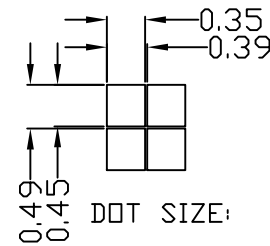
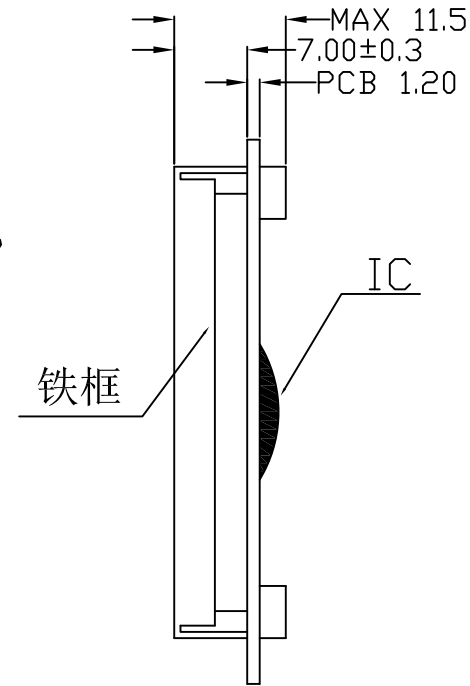
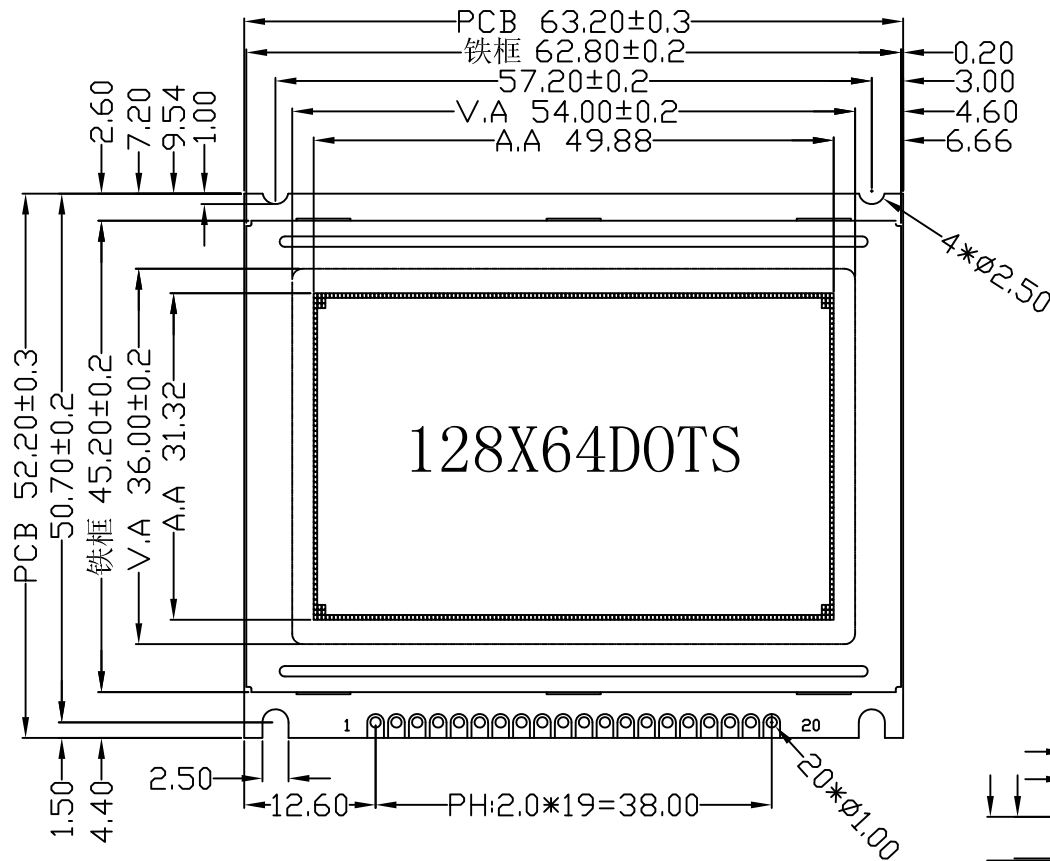

INTERFACE

1	VDD
2	VSS
3	V0
4	DB0
5	DB1
6	DB2
7	DB3
8	DB4
9	DB5
10	DB6
11	DB7
12	CS2
13	CS1
14	RST
15	RW
16	RS
17	E
18	VSS
19	LED-A
20	LED-K

Customer's Choices:

DISPLAY TYPE:	
View angle:	
Temp:	
Voltage:	
IC:	
Backlight:	
Other:	

NOTES:

- | | |
|----------------------------|-------------------------------------|
| 01. DISPLAY TYPE: | STN-BLUE/NEGATIVE/TRANSMISSIVE RoHS |
| 02. OPERATING VOLTAGE: | VOP=8.7V,VDD=5.0V |
| 03. OPERATING TEMPERATURE: | -20°C~+70°C |
| 04. STORAGE TEMPERATURE: | -30°C~+80°C |
| 05. DRIVE MODE: | 1/64DUTY,1/9BIAS |
| 06. VIEWING DIRECTION: | 6:00 |
| 07. DRIVE IC: | AIP31107/31108(OR-EQV) |
| 08. CONNECTOR: | ZEBER |
| 09. BACKLIGHT: | LED(WHITE,I=60MA) |
| 10. CUSTOMER'S PART ID: | BLAZE_STANDARD_PRODUCT |

BLAZE Blaze Display Technology Co.,Ltd.

DESIGNED BY: BDT-21

BGB12864-02-SERIES

VERSION: 1.0

CHECKED BY: BDT-05

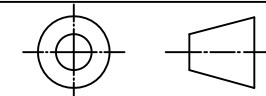

PAGE 1 OF 1

APPROVED BY: BDT-02

UNIT: mm

Website: <http://www.blazedisplay.com>

DATE: 2012-04-27