

INTERFACE:

1	VSS
2	VDD(5V)
3	V0
4	RS
5	RW
6	E
7	DB0
8	DB1
9	DB2
10	DB3
11	DB4
12	DB5
13	DB6
14	DB7
15	LEDK
16	LEDA(21V)

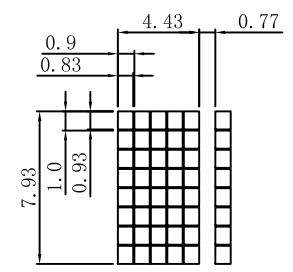
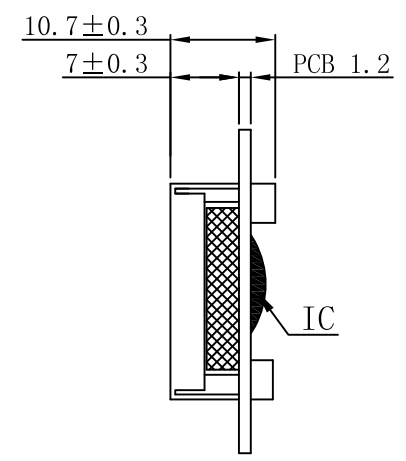
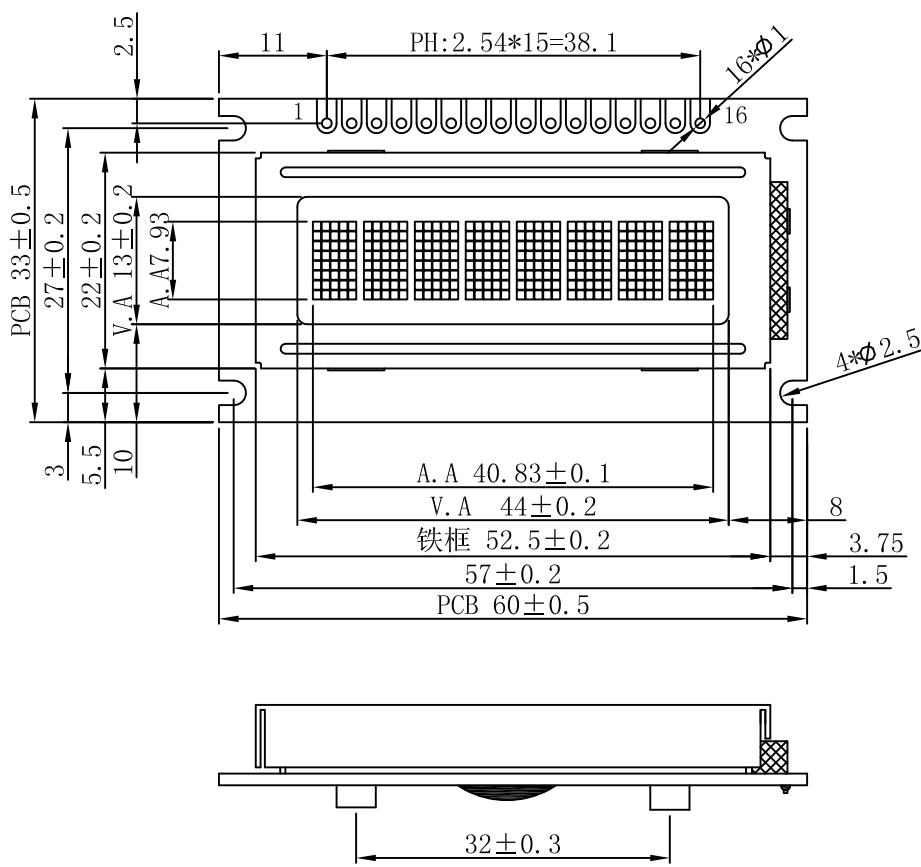

DOT SIZE:

NOTES:

- 01. DISPLAY TYPE: STN/POSITIVE(YELLOW-GREEN)/TRANSFLECTIVE RoHS
- 02. OPERATING VOLTAGE: VOP=3.0V,VDD=5.0V
- 03. OPERATING TEMPERATURE: -30°C~+80°C
- 04. STORAGE TEMPERATURE: -30°C~+85°C
- 05. DRIVE MODE: 1/8DUTY,1/4BIAS
- 06. VIEWING DIRECTION: 6:00
- 07. DRIVE IC: SPLC780B-03A
- 08. CONNECTOR: ZEBER
- 09. BACKLIGHT: LED(YELLOW-GREEN)
- 10. CUSTOMER'S PART ID: BLAZE_STANDARD_PRODUCT

BLAZE Blaze Display Technology Co.,Ltd.

DESIGNED BY: BDT-24	BCB0801-C01	VERSION: 1.0
CHECKED BY: BDT-06		PAGE 1 OF 1
APPROVED BY: BDT-02		UNIT: mm
Website: http://www.blazedisplay.com		DATE: 2013-3-23