

Revised Record

1.0 New Issue

2014-04-19

INTERFACE

| | |
|----|-------|
| 1 | VSS |
| 2 | VDD |
| 3 | V0 |
| 4 | RS |
| 5 | RW |
| 6 | E |
| 7 | DB0 |
| 8 | DB1 |
| 9 | DB2 |
| 10 | DB3 |
| 11 | DB4 |
| 12 | DB5 |
| 13 | DB6 |
| 14 | DB7 |
| 15 | VEE |
| 16 | LED-A |
| 17 | LED-K |
| 18 | VSS |
| 19 | FGND |

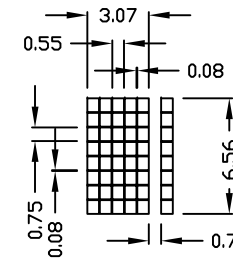
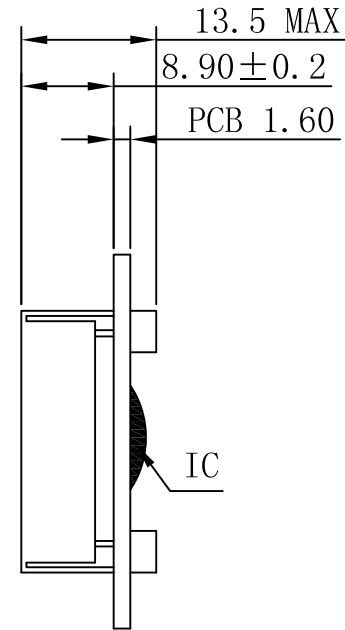
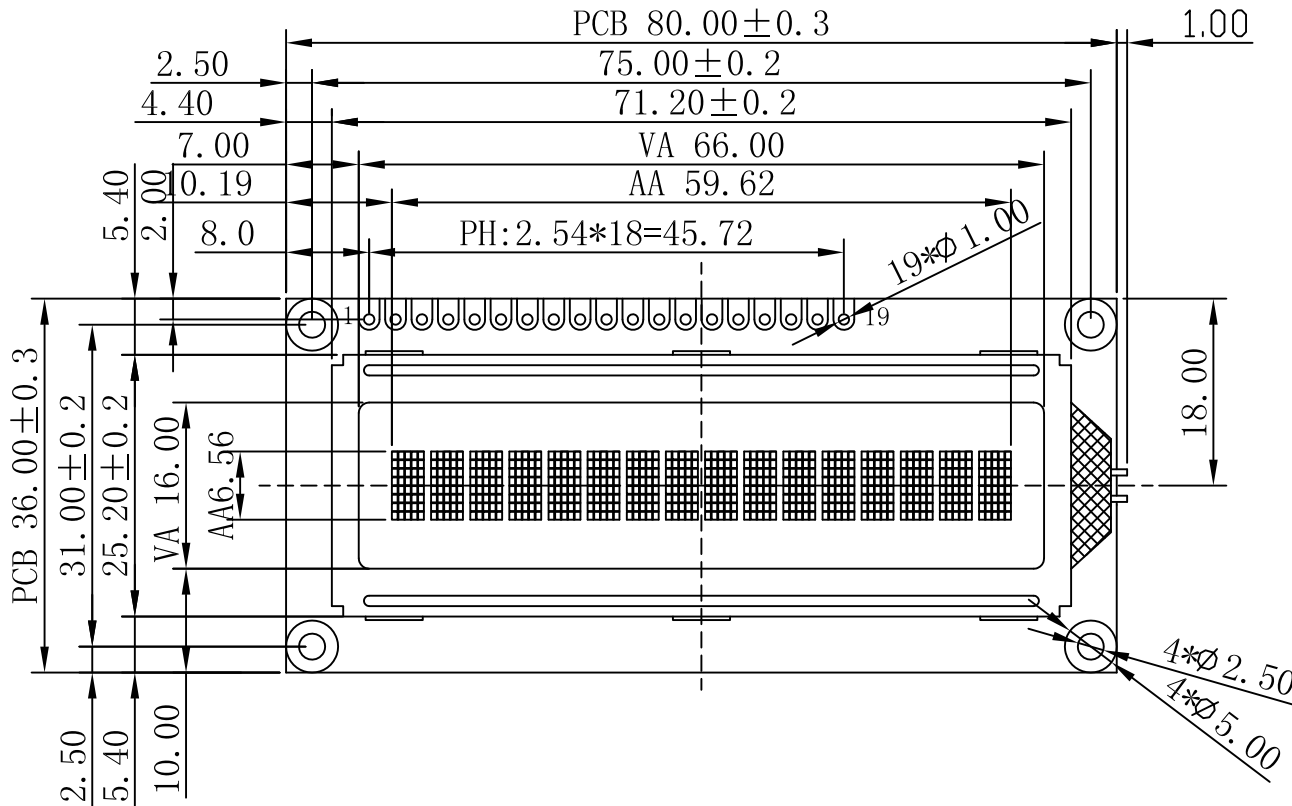

Customer's Choices:

| | |
|---------------|--|
| DISPLAY TYPE: | |
| View angle: | |
| Temp: | |
| Voltage: | |
| IC: | |
| Fonts: | |
| Backlight: | |
| Other: | |

NOTES:

- | | |
|----------------------------|-------------------------------------|
| 01. DISPLAY TYPE: | STN-BLUE/NEGATIVE/TRANSMISSIVE RoHS |
| 02. OPERATING VOLTAGE: | VOP=4.5V, VDD=5.0V |
| 03. OPERATING TEMPERATURE: | -20°C~+70°C |
| 04. STORAGE TEMPERATURE: | -30°C~+80°C |
| 05. DRIVE MODE: | 1/16DUTY, 1/5BIAS |
| 06. VIEWING DIRECTION: | 6:00 |
| 07. DRIVE IC: | ST7066U(OR-EQV) |
| 08. CONNECTOR: | ZEBRA |
| 09. BACKLIGHT: | LED(WHITE) |
| 10. CUSTOMER'S PART ID: | |

BLAZE Blaze Display Technology Co.,Ltd.

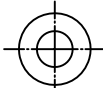
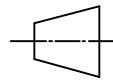
| | | |
|--|---|------------------|
| DESIGNED BY: BDT-14 | BCB1601-01-SERIES | VERSION: 1.0 |
| CHECKED BY: BDT-09 |   | PAGE 1 OF 1 |
| APPROVED BY: BDT-02 | | UNIT: mm |
| Website: http://www.blazedisplay.com | | DATE: 2014-04-19 |